

WINDBACK

ergoseal.com

Applications Include:

- Vacuum pumps
- Blowers
- Compressors
- Other rotating equipment



Self-Centering
and Windback seals.

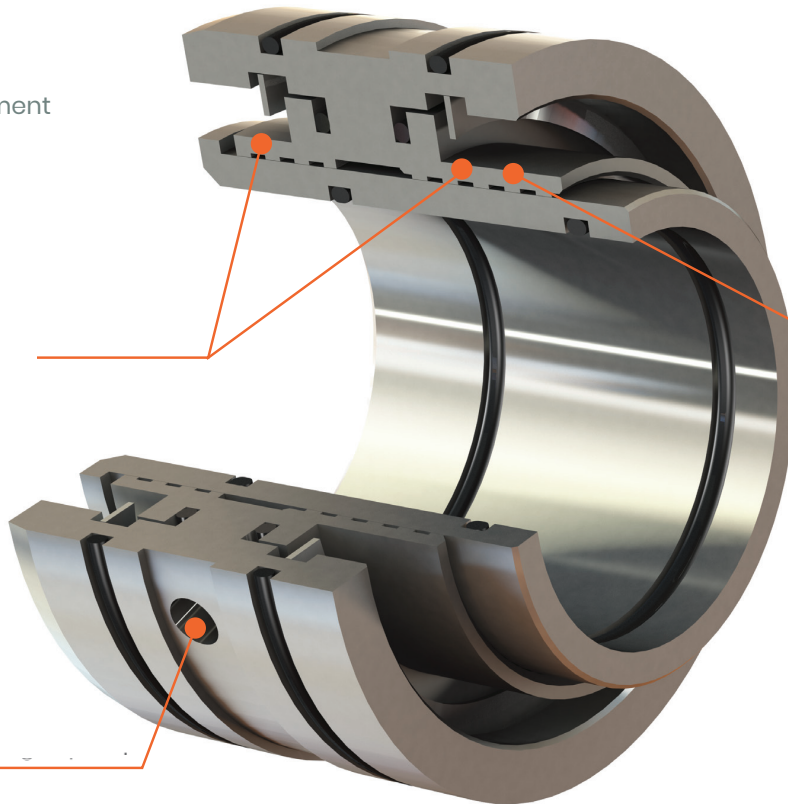

Windback seal utilizes
shaft boundary layer to
seal process oil or gas.

Gas purge option.

VALUE DRIVEN PARTNERSHIP

We design the Windback seal to fit existing seal cavities in your machines. Working with and listening to your personnel, Ergoseal optimizes the performance of the seal for your application.

ZERO POWER DISSIPATION

The Windback seal is used in "oil-free" rotary screw compressors or any other oil-free rotary machines. Type 75 is a non-contacting cartridge shaft seal used to prevent leakage loss of process gas, while simultaneously preventing ingress of lubricating oil to the pumping chamber. Internal elements have the ability to self align radially, achieving essential concentricity with shaft rotational axes.

TO REQUEST A QUOTE CONTACT US AT:
630.462.9600 | Fax 630.462.3600 or send an email to info@ergoseal.com

