

## SERIES 410 STYLE

PTFE lip seals are an alternative that bridges the gap between elastomer lip seals and mechanical carbon face seals, particularly in applications where higher pressure, speeds or other harsh conditions go beyond the capabilities of oil seals.

The typical size range is for shaft diameters from .125" (3 mm) to 10" (254 mm).

### APPLICATIONS INCLUDE:

- » Super higher pressure, low leakage, systems where extreme backup and exclusion is required
- » Suitable for use in hydraulic motors and hydraulic oil component applications

### NORMAL OPERATING CONDITIONS

- » Pressures up to 500 psi ( $\leq 35$  bar)
- » Temperatures from  $-40$  °F to  $500$  °F ( $-40$  °C to  $260$  °C)
- » Rotary speeds up to 5,000 fpm ( $\leq 25.4$  m/s)

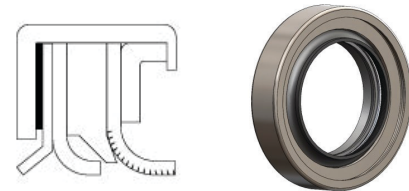

### SEALING LIP (ELEMENT)

- » Fits firmly against the shaft, sleeve or sealing surface
- » Prevents contamination or leakage
- » PTFE based materials compounded with fillers depending on applications parameters and requirements

### GASKET

- » Prevents sealing media leakage between components
- » Assists in component compression
- » Can be rubber or other specialty material

### OUTER CASE

- » Press fit into housing and prevents seal from rotating with the shaft
- » Holds all components in place
- » Custom fit to hardware
- » Materials can be CRS, SS, Aluminum, Brass, or other materials discussed with the engineering team
- » Coating can be applied such as a Boretite and can assist in tighter sealing on bore for less than desired surface finishes, gases, air, or water

### INNER CASE/ RETAINER RING/ SPACER

- » Compresses all the components together and controls the bend radius
- » Usually the same materials as the outer case. Spacer can be aluminum

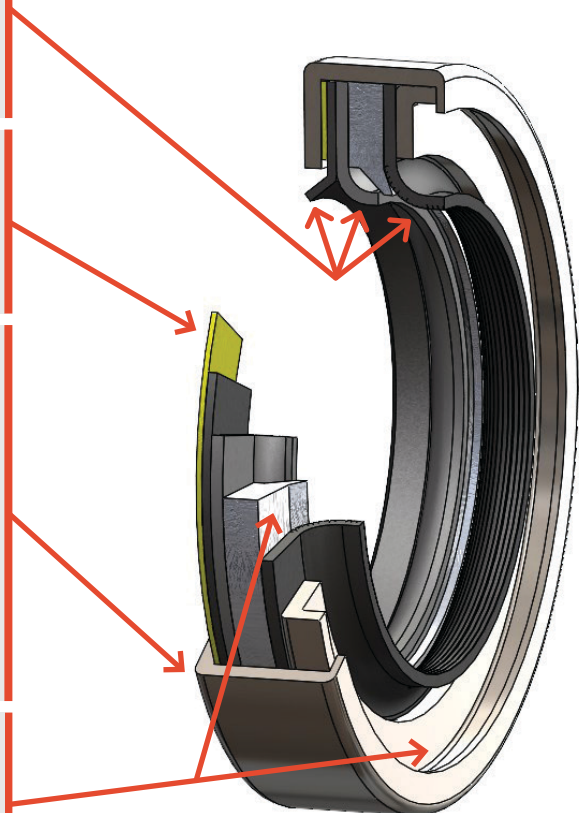

# PTFE LIP SEALS

## FEATURES & MATERIALS

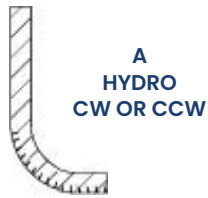

- » Provides a pumping action that can be machined for either a clockwise rotating shaft or a counter clockwise rotating shaft.

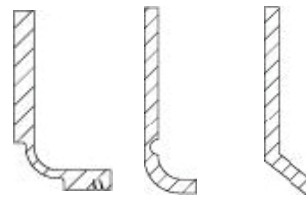

**B FLEX COOL**      **C FLEX LOAD**      **D SPUN FORWARD**

- » Provides lighter loading while maintaining element thickness.
- » Cooling grooves or slots to allow fluid lubrication.

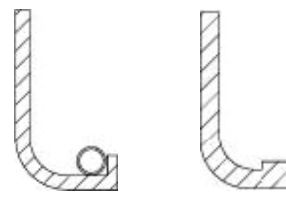
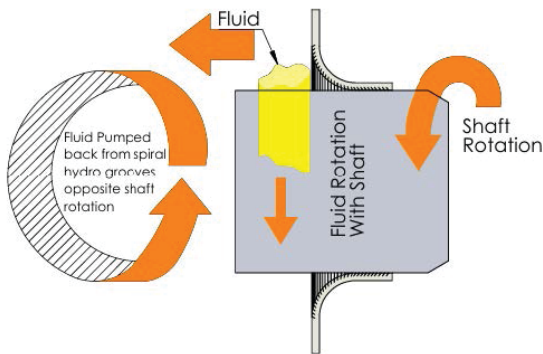

**E RUNOUT**      **F RUNOUT**

- » Provides additional spring or o-ring load to compensate for shaft runout or shaft misalignment.
- » Improves sealing under high speed.

Compound	Color	Temp. (MIN.)	Temp. (MAX.)	Application*	Characteristics	Tensile % Elongation
Virgin	White	-240 °C (-400 °F)	288 °C (500 °F)	Slow dynamic light duty Food & Beverage Application Pharmaceutical Industry	No filler Poor extrusion Poor wear resistance	Tensile Strength: 4500 psi Elongation: 400%
Carbon Filled PTFE	Black	-200 °C (-328 °F)	200 °C (-392 °F)	High Mechanical Stress Rotary Sealing Water/Oil, Hydraulics	High Wear Resistance Creep Resistance	Tensile Strength: 3200 psi Elongation: 300%
Graphite Filled PTFE	Black	-200 °C (-328 °F)	200 °C (-392 °F)	Low Mechanical Stress Soft Sealing Surfaces Good for Water	Higher density for sealing gases	Tensile Strength: 3200 psi Elongation: 277%
EKONOL Filled PTFE	Beige	-200 °C (-328 °F)	200 °C (-392 °F)	Medium Mechanical Stress Softer Sealing Surfaces	Limited Use In Hot Water	Tensile Strength: 2900 psi Elongation: 250%
Polyimide Filled PTFE	Yellow	-240 °C (-400 °F)	288 °C (500 °F)	Softer Sealing Surfaces	Lowest Coefficient of friction Excellent Physical Properties Excellent performance against soft mating surfaces	Tensile Strength: 3200 psi Elongation: 230%
Glass & MOS2 (Moly) Filled PTFE	Grey	-200 °C (-328 °F)	200 °C (-392 °F)	High Speed Rotary Applications High Pressure Rotary Applications	High Creep Strength High Chemical Resistance Outstanding Wear Resistance Excellent extrusion resistance for high pressure application	Tensile Strength: 4300psi Elongation: 250%
Carbon Fiber Filled PTFE	Black	-200 °C (-328 °F)	200 °C (-392 °F)	Aqueous Environment	Excellent Wear Resistance Properties In Water Dynamic Applications At High Speed Excellent Compressive Strengths	Tensile Strength: 2900 psi Elongation: 180%
Glass Fiber Filled PTFE	Yellow	-200 °C (-328 °F)	200 °C (-392 °F)	Air Compressor	Electrical Properties Like Virgin PTFE High Creep Resistance	Tensile Strength: 3200 psi Elongation: 315%
Mineral Filled PTFE (FDA)	White	-240 °C (-400 °F)	288 °C (500 °F)	Food & Beverage Application Pharmaceutical Industry	Excellent Performance under Non- Lubricated Environment	Tensile Strength: 2400 psi Elongation: 250%

\*Applications are for references, not limited to

To request a quote, contact us at 630.462.9600 or [info@ergoseal.com](mailto:info@ergoseal.com)

[www.ergoseal.com](http://www.ergoseal.com)